

**DUAL MODE GOVERNOR FOR
IN-FLIGHT VARIABLE PITCH PROPELLER
WITH ELECTRIC HUB
FOR ULM**

DLM-GOV

**INSTALLATION AND USE
MANUAL**

For SW Version 4.24 or higher – Serial number G0XXXX

 fp propeller AIRCRAFT AND UAV PROPELLERS	USER MANUAL	Code	MAN-0002e
		Revision #	02
		Last revision date	08/04/2020
Page 2 / 25	DUAL MODE GOVERNOR [DLM-GOV]		

N.B. THIS DEVICE IS WITHOUT CERTIFICATION. ANY RESPONSABILITY IN THE USE OF THIS DEVICE IS IN CHARGE TO THE USER

Article 1. law 106 / 85:

The pilot must to comply to laws, regulations and requirements of the authorities. In addition, before and during the flight, he must personally ensure that the flight can take place safely. He must take into account the weather conditions, the efficiency of the appliance, of his own psycho-physical conditions, training, and all other circumstances of time and place, and consequently to determine the action to be taken in order that the flight does not result dangerous for his own or others' safety.

LIMITED WARRANTY

The products of FP-PROPELLER S.R.L. which are sold disassembled, must be mounted and used as indicated in the instruction manual provided. Failure to follow these instructions will void, deletes all liability of FP-propeller S.r.l.

The user always flies in full responsibility, as specified in Law 106/85 and later D.P.R. n. 133 of 2010 in particular Art. 1 and 3

Our products do not contain user replaceable parts.

The product warranty conditions are explain in the SALES CONDITIONS attached.

Contents:

1. Introduction:	4
2. NOTICES AND IMPORTANT NOTES	5
3. SYMBOL USED	6
4. PANEL OVERVIEW:	7
5. INSTALLAZIONE	7
5.1 Mechanical installation:	7
5.2 Electrical installation and MAP connection.....	8
6. MAIN FUNCTIONS	10
7. GOVERNOR SETUP / ENGINE SELECTION	10
8. OPERATING MODES	13
8.1 CONSTANT RPM OPERATION	13
8.2 MDP DRIVEN OPERATION.....	14
8.3 MANUAL OPERATION.....	15
9. AUTO TAKE-OFF FUNCTION	16
10. ALARMS	17
10.1 OVERLOAD ALARM.....	17
10.2 MINIMUM PITCH LIMIT ALARM	17
11. CHECK LIST	19
12. FLIGHT TEST	21
13. TECHNICAL SPECIFICATIONS	23
14. SALES CONDITIONS	24

1. INTRODUCTION:

The heart of the device is a latest generation microcontroller (CPU), which works with the goal of maintaining constant engine speeds. The software reads sensor signals, processes data and decides on this basis.

To make this process so fast, the software consists of several blocks, each of which operates autonomously in parallel to others.

The main features of the Dual Mode Governor are:

"Constant speed" mode, where the rider chooses the rpm target by rotating the potentiometer (CNST)

"MDP driven" automatic mode, where the target rpm value is determined by the pressure difference (MDP) between the manifold pressure and the atmospheric pressure outside the aircraft. This pressure difference is changed each time the gas handhold is changed. That is, when you change the engine power. This second mode operates in a fully automated manner, requiring no pilot command intervention.

The use of the engine characteristic curve integrated in the CPU ensures the maximum efficiency of the couple propeller / engine

As well-known, it is noted that atmospheric pressure decreases with height. The higher map values available at low altitude are no longer available at high altitudes. Our governor, using the mdp, is fully compensated for the height. In practical terms, the engine continues to maintain the rpm value set when the height changes. So, keep on the best possible power available.

Of course, manual control mode is also available, where the propeller pitch is directly controlled by the pilot.

For the take-off phase only, the maximum rpm value is incremented automatically according to the engine manufacturer's instructions and for a three-minute time. (This function could be excluded in setup phase)

The Dual Mode Governor works in automatic mode with the most used ULM engines: Rotax, UL Power.

The CPU stores in the memory the characteristic data of the various engines.

 fp propeller AIRCRAFT AND UAV PROPELLERS	USER MANUAL	Code	MAN-0002e
		Revision #	02
		Last revision date	08/04/2020
Page 5 / 25	DUAL MODE GOVERNOR [DLM-GOV]		

2. NOTICES AND IMPORTANT NOTES

- The instrument can only be used on ultralight and experimental aircraft.
- Has no aeronautical certification.
- Consult the applicable legislation in your country before deciding on your installation.
- Read this manual completely, which must be kept on board.
- Always comply with the installation and use instructions.
- Do not use this instrument in flight until you are sure it is working properly.
- After the installation is completed, perform an accurate, ground test, checking the correct operation of the instrument.
- The software of this tool can be updated, modified by adding or removing functions. Operation can therefore be subject to change. Without prior notice and without obligation to apply such modifications retroactively
- Always refer to the updated installation and use manual for the software version used. To obtain manuals and updates, please contact Fp-Propeller S.r.l.
- **The user always flies in full responsibility, as specified in Law 106/85 and later D.P.R. n. 133 of 2010 in particular Art. 1 and 3 As the installer assumes responsibility for the installation.**
- The Fp-propeller has no control over the installation, maintenance, and can't check how DUAL MODE is used, so it is considered to be relieved of any civil and penal liability.
- Take-off and reattach maneuvers for safety issues must be made with the DUAL MODE GOVERNOR in Manual Mode.

 fp propeller AIRCRAFT AND UAV PROPELLERS	USER MANUAL	Code	MAN-0002e
		Revision #	02
		Last revision date	08/04/2020
Page 6 / 25	DUAL MODE GOVERNOR [DLM-GOV]		

3. SYMBOL USED

This Manual uses the following symbols to emphasize particular information. This information is important and must be observed.

 **WARNING** Identifies an instruction which, if not followed, may cause serious injury including the possibility of death.

 **CAUTION** Identifies an instruction which, if not followed, may cause minor or moderate injury.

 **NOTICE** Denotes an instruction which, if not followed, may severely damage the engine or other components.

4. PANEL OVERVIEW:

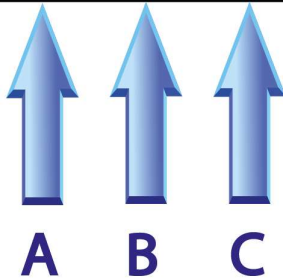
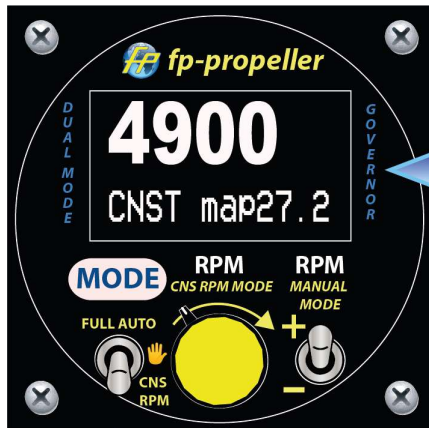

A= Mode Selection

MDP Driven

Manual

Constant RPM

B= Rotating knob to set the target RPM in
CONSTANT RPM MODE

C= Switch increase or decrease the RPM in
MANUAL MODE

D= OLED DISPLAY

5. INSTALLAZIONE

5.1 Mechanical installation:

The DUAL MODE GOVERNOR fit a standard 2 "1/4 (57mm) hole through 4 x M4 screws. Thanks to the wide viewing angle of the oled display, the installation is more flexible. However, it's important to make it easy to use the panel controls.

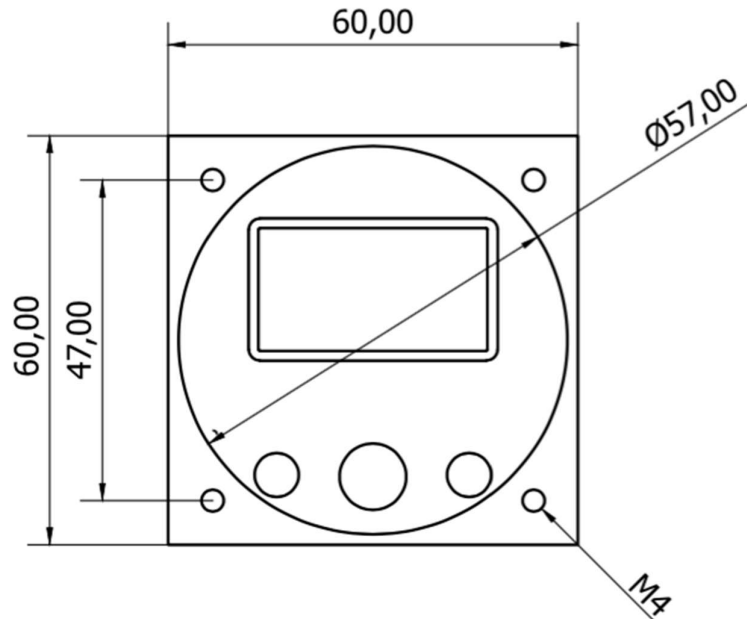

5.2 Electrical installation and MAP connection

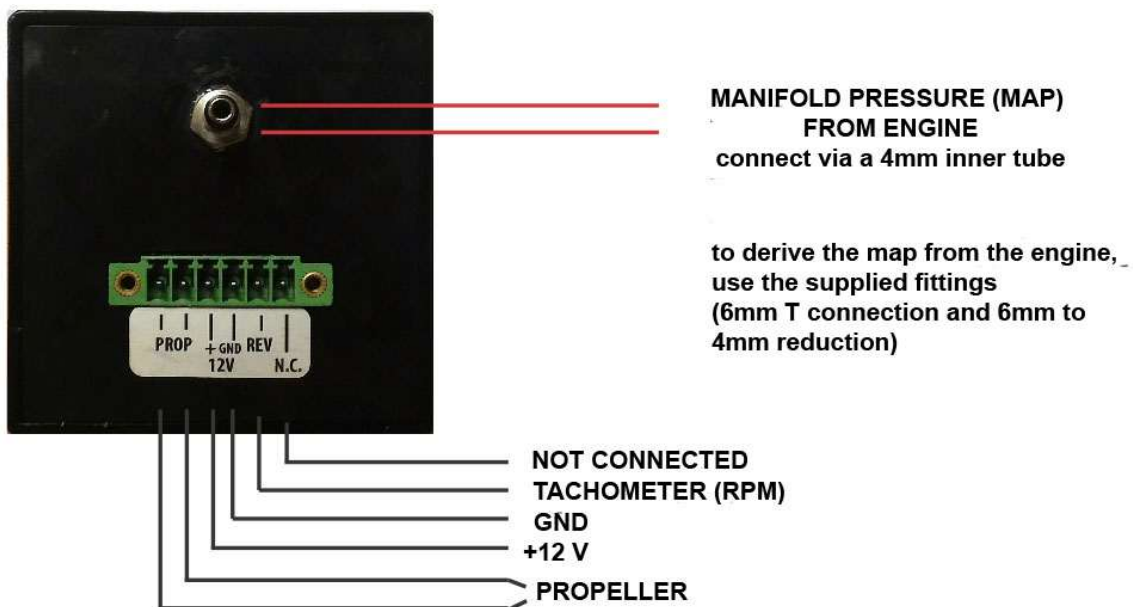

⚠ WARNING

After connecting as shown in the diagram, with the switch (A) in the center position (manual mode), move the propeller pitch via the switch (C) and check if the direction of operation is correct.

In detail: switch up => it must decrease the pitch

Switch down => it must increase the pitch.

If that is not the case, invert the 2 wires that connect the propeller to the governor's terminal block.

⚠ WARNING

INSERT A 5A BREAKER ON THE GOVERNOR POWER SUPPLY LINE.

⚠ CAUTION

The DUAL MODE GOVERNOR is designed to operate with "Fp propeller" propellers, or other variable pitch propellers with electric servomotor and end of run switches, according to the following diagram:

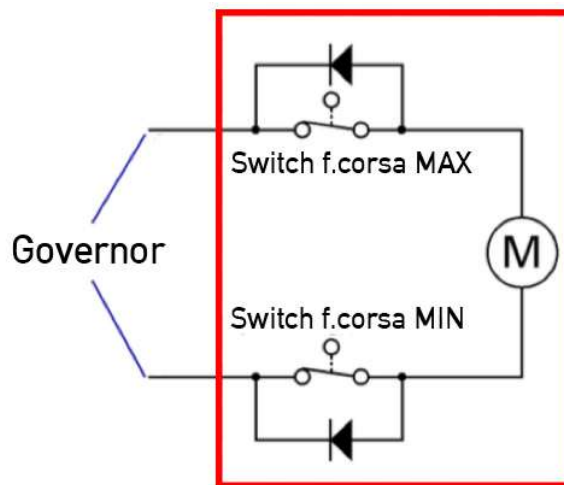

	USER MANUAL	Code	MAN-0002e
		Revision #	02
		Last revision date	08/04/2020
Page 10 / 25	DUAL MODE GOVERNOR [DLM-GOV]		

6. MAIN FUNCTIONS

- 3 modes available: CONSTANT RPM, FULL AUTOMATIC (MDP DRIVEN), MANUAL
- OLED graphic display with wide visibility angle
- OVERCURRENT alarm for current absorption > 4A
- Protective fuse (5A time delay)
- Return to the minimum pitch when the Governor is switched on
- Control range from 4000 to 5500 RPM (for Rotax engines)
- Automatic take-off function (could be disabled)
- MDP DRIVEN mode compensated for altitude

7. GOVERNOR SETUP / ENGINE SELECTION

Holding the switch (C) downwards, power the governor.
Hold down for 5 seconds.

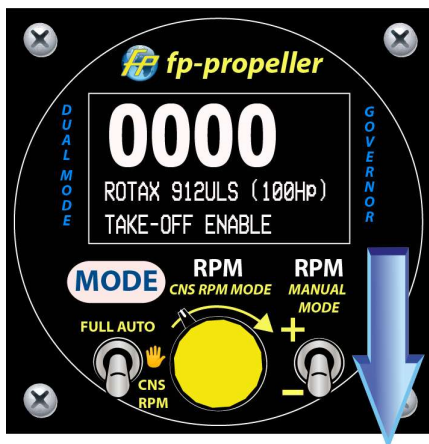

The following screen appears:

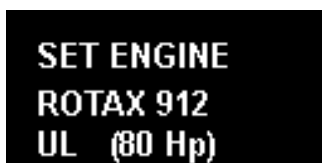

At each press of the switch (C) **upwards** for at least 1 sec. the selected engine change.

When the display shows the engine installed on the aircraft, confirm by holding down the switch (C) **for 3 seconds** until the next screen appears. In this way, the governor loads from his database the operating parameters for the selected engine.

Subsequently, setup allows you to choose whether to use the AUTO TAKE-OFF function (automatic take-off recognition).

**SET ENGINE
AUTO TAKE-OFF
ENABLE**

NOTICE

The possible choices are:

AUTO TAKE-OFF ENABLE: The system allows to reach 5800 RPM for only 1 time after switching on and for a maximum of 3 minutes

See Section 9 for a detailed description of this function.

AUTO TAKE-OFF DISABLE: If the AUTO TAKE-OFF function is excluded, the system will always adjust between 4000 and 5500 Rpm (for Rotax engines)

MAX 5600 RPM: The automatic TAKE-OFF function is excluded, the system allows to reach 5600 RPM (for Rotax engines). The adjustment range is 4100-5600 Rpm.

MAX 5700 RPM: The automatic TAKE-OFF function is excluded, the system allows to reach 5700 RPM (for Rotax engines). The adjustment range is 4200-5700 Rpm.

MAX 5800 RPM: The automatic TAKE-OFF function is excluded, the system allows to reach 5800 Rpm (for Rotax engines). The adjustment range is 4300-5800 Rpm.

	USER MANUAL	Code	MAN-0002e
		Revision #	02
		Last revision date	08/04/2020
Page 12 / 25	DUAL MODE GOVERNOR [DLM-GOV]		

At each press of the switch (C) **upwards** for at least 1 sec. The display rotates between the 5 possible choice.

When the display shows the desired value, confirm by **holding down the switch (C) down for 15 seconds until "OK" appears.**

⚠ WARNING

The **AUTO TAKE-OFF ENABLE** and **AUTO TAKE-OFF DISABLE** modes ensure compliance with the Rotax specifications about maximum allowed time over 5500 Rpm.

In the **MAX 5600 RPM, MAX 5700 RPM, MAX 5800 RPM** modes, the responsibility to comply with the Rotax specifications is delegated to the pilot who will then have to adjust the governor accordingly.

In addition, in MDP DRIVEN mode and with **AUTO TAKE-OFF ENABLE** or **AUTO TAKE-OFF DISABLE**, the system uses the MAP / RPM curve that maximizes engine efficiency.

In the **MAX 5600 RPM, MAX 5700 RPM, MAX 5800 RPM** modes, an offset of 100Rpm, 200Rpm, 300Rpm was added to allow the selected MAX RPM to be reached.

⚠ WARNING

To check the correct installation and proper operation of the system, after reading the manual, proceed with the checklist on chapter 11

	USER MANUAL	Code	MAN-0002e
		Revision #	02
		Last revision date	08/04/2020
Page 13 / 25	DUAL MODE GOVERNOR [DLM-GOV]		

8. OPERATING MODES

At power-on, the display shows for a short period the selected setup parameters: ENGINE, ENABLED or DISABLED TAKE-OFF, MAX RPM

8.1 CONSTANT RPM OPERATION

Move the switch (A) downwards.

NB: The switch (A) has the safety lock against involuntary maneuvers, the lever must be pulled in order to move it

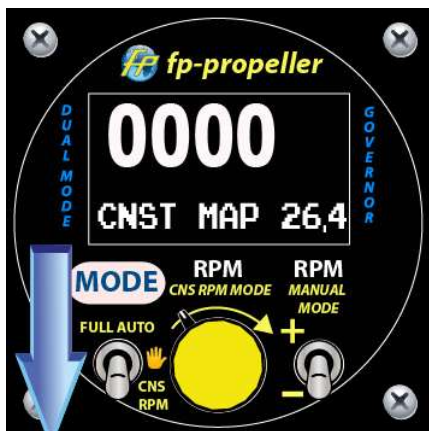

In this mode, the pilot decides the target RPM by turning the potentiometer (B) and the governor moves the propeller pitch to reach that target value. The Governor maintains that target value independently of the handle, within the limits set by the aircraft, the propeller and the flight conditions. The setting range for Rotax engines ranges from 4000 to 5500 RPM (4300 to 5800 RPM in takeoff mode, please check chapter 7 for other modes)



 fp propeller AIRCRAFT AND UAV PROPELLERS	USER MANUAL	Code	MAN-0002e
		Revision #	02
		Last revision date	08/04/2020
Page 14 / 25	DUAL MODE GOVERNOR [DLM-GOV]		

The value shown in the OLED display is the TARGET RPM value, the system has a hysteresis of ± 100 rpm to avoid unnecessary stresses on the propeller's servomotor, so the actual RPM value may differ by ± 100 rpm. A flashing arrow indicates whether the system is increasing or decreasing RPM to reach the target.

If the arrow remains fixed and empty, it means that its limit switch has been reached.

At the bottom right of the display, the system indicates the value of the MAP (inHg).

⚠ CAUTION Before taking off, we recommend turning the potentiometer (B) all the way clockwise even if you are using the fully automatic mode (MDP DRIVEN MODE)

8.2 MDP DRIVEN OPERATION (FULL AUTOMATIC)

Move the switch (A) upwards.

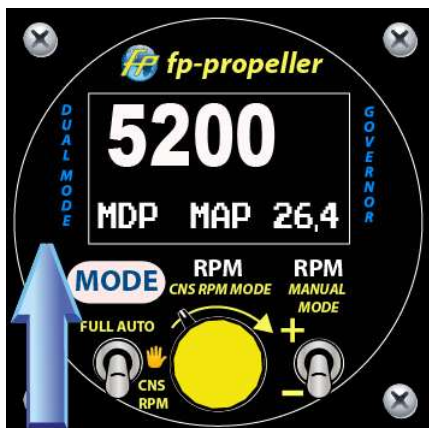

	USER MANUAL	Code	MAN-0002e
		Revision #	02
		Last revision date	08/04/2020
Page 15 / 25	DUAL MODE GOVERNOR [DLM-GOV]		

In this mode, the system adjusts the pitch completely automatically based on the MDP-RPM TARGET curve inserted in the microcontroller for the selected engine.

The setting range for Rotax engine ranges from 4000 to 5500 RPM (5800 RPM in takeoff mode, please check chapter 7 for other modes)



The value shown in the OLED display is the **TARGET RPM** value, the system has a hysteresis of ± 100 rpm to avoid unnecessary stresses on the propeller servomotor, so the actual RPM value may differ by ± 100 rpm

A flashing arrow indicates whether the system is increasing or decreasing RPM to reach the target.

If the arrow remains fixed and empty, it means that its limit switch has been reached.

At the bottom right of the display, the system indicates the value of the MAP (inHg).

The system adjusts on the basis of the Manifold differential pressure (MDP), that is the difference between the MAP and the QFE read by the second Governor pressure sensor.

This allows the system to be compensated for the altitude and to allow to reach 5500 RPM at any flight quote.

8.3 MANUAL OPERATION

Move the switch (A) to the center position.

In this way, the propeller servomotor is directly controlled by the switch (C) without the governor's operation.

	USER MANUAL	Code	MAN-0002e
		Revision #	02
		Last revision date	08/04/2020
Page 16 / 25	DUAL MODE GOVERNOR [DLM-GOV]		



The display indicates **actual RPMs** and, during propeller motion, the power consumption of the servomotor of the propeller (Ampere), as a diagnostic of the correct functioning of the system.

Switch (C) upwards = + RPM = -pitch

Switch (C) downwards = - RPM = + pitch

A flashing arrow indicates whether the system is increasing or decreasing RPMs in accordance with the direction of the switch (C).

If the arrow remains fixed and empty, it means that its limit switch has been reached.

9. AUTO TAKE-OFF FUNCTION

In the MDP DRIVEN and CONSTANT RPM modes, and only once after turning on the instrument, the TAKE-OFF AUTOMATIC function is activated.

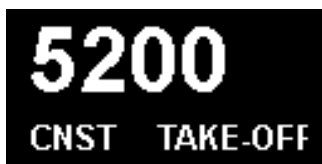

Once the 5000 RPM is exceeded and for 3 minutes (in the case of Rotax engines), the system adds an offset of +300 RPM to the TARGET RPM calculated by the system (MDP DRIVEN) or set by the pilot (CONSTANT RPM) so the engine can reach 5800 RPM for the take-off phase.

The TAKE-OFF word appears at the bottom of the display during these 3 minutes.

This functionality could be excluded during initial setup.

10. ALARMS

10.1 OVERLOAD ALARM

⚠ WARNING

IN ALL MODES IT IS IMPLEMENTED OVERLOAD ALERT FOR ABSORPTIONS > 4A.

IN THAT CASE "OVERLOAD" WARNING APPEARED ON THE DISPLAY, AND THE GOVERNOR WILL ENTER IN A BLOCK STATE TO avoid aggravating the existing problem.

**⚠ WARNING**

It is necessary to remove the causes of excessive current absorption.

When rebooted, the governor will work regularly

⚠ WARNING

Manual mode, not being controlled by the microprocessor (for safety reasons) allows to move the propeller pitch even in the case of OVERLOAD

10.2 MINIMUM PITCH LIMIT ALARM

At power up, the system automatically brings the propeller to the minimum pitch, in preparation for take-off.

If the system does not identify the limit switch within the set time (due to a possible breakage of the same), it will maintain the arrow flashing upwards in order to indicate the problem.

	USER MANUAL	Code	MAN-0002e
		Revision #	02
		Last revision date	08/04/2020
Page 18 / 25	DUAL MODE GOVERNOR [DLM-GOV]		



ARROW ALWAYS FLASHING





The system will still work correctly, except to arrow pointing upwards always flashing.



When switched on again, the alarm status will be reset.

After this alarm, it is essential to verify the correct operation of the microswitch of the minimum pitch.

11. CHECK LIST

	TEST DESCRIPTION	EXPECTED RESULT	OBTAINED RESULT
1	Turn on the cockpit with the governor in the MDP position The display must show: 5500, Map 30.0 (+/- 1)	OK	
2	Connection check: in MANUAL position, Switch  = -pitch = +RPM Switch  = +pitch = -RPM (If not, invert the two signals in the propeller governor connector) Read the Amps shown, reach minimum and maximum limit switch, the up and down arrows must remain on, blank, to indicate that it has detected the corresponding limit switches 	0,8-1,5A (fp-propeller hub)	
3	Turn on the engine in MANUAL position, Switch  = - pitch = +RPM Switch  = + pitch = -RPM Read the Amps shown	0,8-1,5A (per mozzo fp-propeller)	
4	Switch to CONSTANT SPEED (CNST), turn the knob (B) until 4900 RPM, push the throttle until the engine reach 4900 RPM (+/- 100RPM)	4900	
5	Turn the knob (B) up to 4200 RPM without moving the throttle, the governor will control the pitch to reach 4200 RPM (+/- 100RPM)	4200	

6	Turn off the engine and the cockpit, turn on the cockpit with the governor set in the MDP position, the governor must automatically move the propeller to the minimum pitch, the upward arrow must remain on (empty) to indicate that the minimum switch limit has been reached 	OK	
7	Turn on the engine, the governor have to show a value of MAP <20	<20	
8	Push the throttle up to around 3000 rpm check that the MAP increase	OK	
9	Push the throttle up to 4000 rpm, map value have to be 24,5 +/-0,5	24,5	
10	Push the throttle up to 4900 rpm, map value have to be 27 +/-0,5	27	
11	Push the throttle over 5000 rpm, the display have to show "TAKE OFF" in the lower part	OK	
12	At full throttle, the engine have to reach 5800 RPM with a map value >28	>28	

Note: all MAP values refer to a test at altitude 0 and atmospheric pressure 1 BAR = 30 inHg, if the atmospheric pressure is different (by altitude or climatic) the results of points 9, 10, 12 must be scaled consequently
 The controller is based on the MDP (Differential Pressure of the manifold), so the minimum deviations of the MAP from the above values are not symptoms of malfunction, but only the tolerance of the 2 pressure sensors (precision =1/4 inHg)

12. FLIGHT TEST

After performing the test of the previous checklist with a positive result, the flight test is carried out. This test must be carried out under simplified conditions, for safety purposes. The conditions described refer to the Rotax engine. For other engines, adjust the values as from the engine specification. With the governor in CONSTANT RPM mode, give current without turning on the engine; move knob B until the target value of 4,900 RPM is displayed on the display. , Turn on the engine, and after heating, align the track and, keeping the airplane fully restrained, give throttle progressively; keep the condition until pitch correction is completed and the target RPM value has been obtained (few seconds).

Without changing the throttle, switch the governor to MANUAL mode; therefore, reduce the throttle. So we've got the propeller pitch that lets you take off in manual mode, but without getting overspeed after taking off. In practice, the variable pitch propeller will act like a fixed propeller.

By holding the MANUAL mode, give throttle and take off, with the same technique used for the fixed propeller. Reach the cruise quota, level and give adequate throttle for cruising RPMs.

Test the governor in CONSTANT RPM mode

We are in leveled cruising flight, Manual mode. Take note of the MAP and RPM values. Switch to CONSTANT RPM mode and change the target RPM value to the cruise value previously used (knob B). After a possible pitch correction, visible from the display, and also depending on the pilot's reaction time in commuting / adjusting, the flight continues steady.

Now, using small variations, you can try various MAP / RPM conditions to find the ones that give you the most satisfying aircraft performance.

To land, set the RPM target to the maximum and reduce the throttle.

In case of any doubt or malfunction, switch to MANUAL mode and return the MAP to the previously marked cruise value. Then, change the propeller pitch until you get the RPM value first noted. In this condition, you can then land simply by reducing the throttle.

	USER MANUAL	Code	MAN-0002e
		Revision #	02
		Last revision date	08/04/2020
Page 22 / 25	DUAL MODE GOVERNOR [DLM-GOV]		

Test the governor in MDP DRIVEN mode

We are in level cruising flight, MANUAL mode or CONSTANT RPM. Note the MAP and RPM values. Switch to MDP DRIVEN mode. After a possible step correction, visible on the display, the flight continues steady. Change the throttle or trim and observe the variations of MAP and RPM consequent. The pitch of the propeller is automatically adjusted without the pilot's intervention. To land, simply reduce the throttle properly.

In case of any doubt or malfunction, switch to MANUAL mode and return the MAP value previously marked. Then, change the propeller pitch until you get the RPM value first noted. In this condition you can then land simply by reducing the throttle.

Please note that, for safety reasons, take-off, reattachment and landing operations must be carried out with Governor Dual Mode in manual and with intermediate pitch.

 WARNING Please note that, for safety reasons, take-off, reattachment and landing operations must be carried out with Governor Dual Mode in manual and with intermediate pitch.

 fp propeller AIRCRAFT AND UAV PROPELLERS	USER MANUAL	Code	MAN-0002e
		Revision #	02
		Last revision date	08/04/2020
Page 23 / 25	DUAL MODE GOVERNOR [DLM-GOV]		

13. TECHNICAL SPECIFICATIONS

- **Display:** OLED graphic 1,3" , high viewing angle
- **Installation:** Standard 2 1/4 "(57mm) hole
- **Case:** Anodised aluminum.
- **Dimensions:** H60,0 x L60,0 x P109mm.
- **Weight:** 240 g.
- **Operating temperature:** -10 ~ +70°C.
- **Supply Voltage:** da 11 a 20 VDC.
- **Current consumption:** 90 mA.
- **Maximum output power :** 4A.
- **Tachometer operating range:** from 500 to 7000 RPM.
- **Tachometer resolution:** 100 RPM.
- **MAP Display resolution:** 0,2 inHg
- **MDP reading resolution:** 0,25 inHg
- **Internal fuse:** 5A Time delay

 fp propeller AIRCRAFT AND UAV PROPELLERS	USER MANUAL	Code	MAN-0002e
		Revision #	02
		Last revision date	08/04/2020
Page 24 / 25	DUAL MODE GOVERNOR [DLM-GOV]		

14. SALES CONDITIONS

1- SALES are made under the general conditions of the selling Company. They can not be altered unless by the selling Company and by written document. All sales are intended as to be "subjected to approval by the seller". Within 15 days fro receipt of the purchase order, the seller will send wrtten confirmation.

Fp-propeller Srl reserves the right to refuse the order.

2- ESTIMATES AND TECHNICAL DATA. Estimates by the seller are not binding. Illustrations, measurements, weights and all the characteristic data resulting from catalogs must be considered as approximate values. They are communicated by the seller for information only and without responsibility. The seller reserves the right to make changes to its products without prior notice and without obligation to apply such changes retroactively.

3- DELIVERY. The sold material will be delivered as soon as possible, subject to the commitments outstanding and to the possibility of production by the factory. The delivery time is therefore only indicative term. It does not constitute an essential condition of the contract. .The delivery term is adequately extended by effect of events independent from the will of the supplying company. In any case, the customer may not claim damages or other related to late delivery.

4- TRANSPORT. The sale of goods is carried out "ex works." It travels under full risk and peril of the customer. The eventual loss or damage of the goods shall not give rise to claims to the seller for damages. The transport insurance will only be made if requested by the customer and at his charge; The request of insurance must be made explicit in the order.

5 PRICES AND TERMS OF PAYMENT. FP-propeller Srl. may modify its prices at any time. The payments of the supply must be made within the period reported in the order confirmation, signed for acceptance by the customeer. For any dispute concerning the material supplied or for any other divergence the Buyer may not suspend payments. Failure to pay the agreed price even for only one part, the non-compliance with contractual obligations and failure by the buyer of one of the above conditions, entitle FP-propeller Srl to obtain immediate completion of all obligations assumed by the buyer, or termination of the contract being worth this as a termination clause about. Delay in paying in the agreed deadlines by the Purchaser, entitles the supplier to apply the monthly interest at the reference rate EURIBOR + 5 points.

6- TERMINATION. In case of contract termination due to breach, the payments in advance already done will remain acquired by the seller Company as indemnity, except the eventual more damage. In any case it will be due to the seller, as a penalty, a sum equal to 15% of the value of sold material, always subject to the most damage.

7-RESERVE OF PROPERTY. The seller, according to Article 1523 Cod. Civ., keeps the property of the material sold until the full pyment of the agreed price. Therefore, the object of the supply will pass to the Buyer property only with the completion of the amount due, while assuming the same risks from the time of delivery. Under request of the seller and in charge to the buyer, it will be provided to all the formalities required by art. 15234 Cod .. Civ. for which the buyer agrees the same at any time.

8-WARRANTY. Products of the FP-PROPELLER S.R.L. They must be installed, maintained and used as specified in the instruction manual provided. Failure to follow these instructions cancels, erases all the responsibility for FP-propeller Srl. The propeller user always flies under his entire responsibility. The Company FP-propeller Srl guarantees its products for six months

after delivery. The warranty covers free repair or replacement of parts that presented established defects in materials, construction, or workmanship; it takes place after examining and finding faults and their causes, to be made by the seller and at its workshops or in those which are authorized to do so. The costs of any inspections, granted by the seller, for transportation to repair or replace, as well as the hand work for the installation thereof shall on charge of the buyer. The warranty is not transferable to third sub-buyers and ceases if products are used in a manner inconsistent with the instructions of the house; if they are dismantled, repaired, modified, also in part, without the permission and the control of the seller or its delegates. All parts subjected to wear and tear during the use are not covered by the warranty.. For parts not manufactured by the seller, the warranty is supplied directly from the manufacturer of the part itself. In any case, it is limited to the warranty limits granted by that manufacturer. Furthermore, the use of the propellers for the flight must be made by applying strictly the instructions and the control procedures, to ensure maximum safety. **Therefore, under no circumstances, the buyer may demand compensation for any damages due to the use of the propeller.**

- 9- COMPLAINTS. Any complaint must be received by the supplier within eight days of receipt of goods by the customer. Claims for breakages or missing parts compared to the delivery document should be communicated to the carrier upon receipt. The complaint does not release the buyer from the obligation to withdraw other regularly ordered goods ready for delivery or allow him to reduce or suspend the payments agreed
- 10- JURISDICTION for all disputes related to this contract, both parties Buyer and Supply recognize the competence of FERRARA COURT